

## Chafe Chain Arrangement

### Chafe Chain A for Ship over 350,000 ton DWT

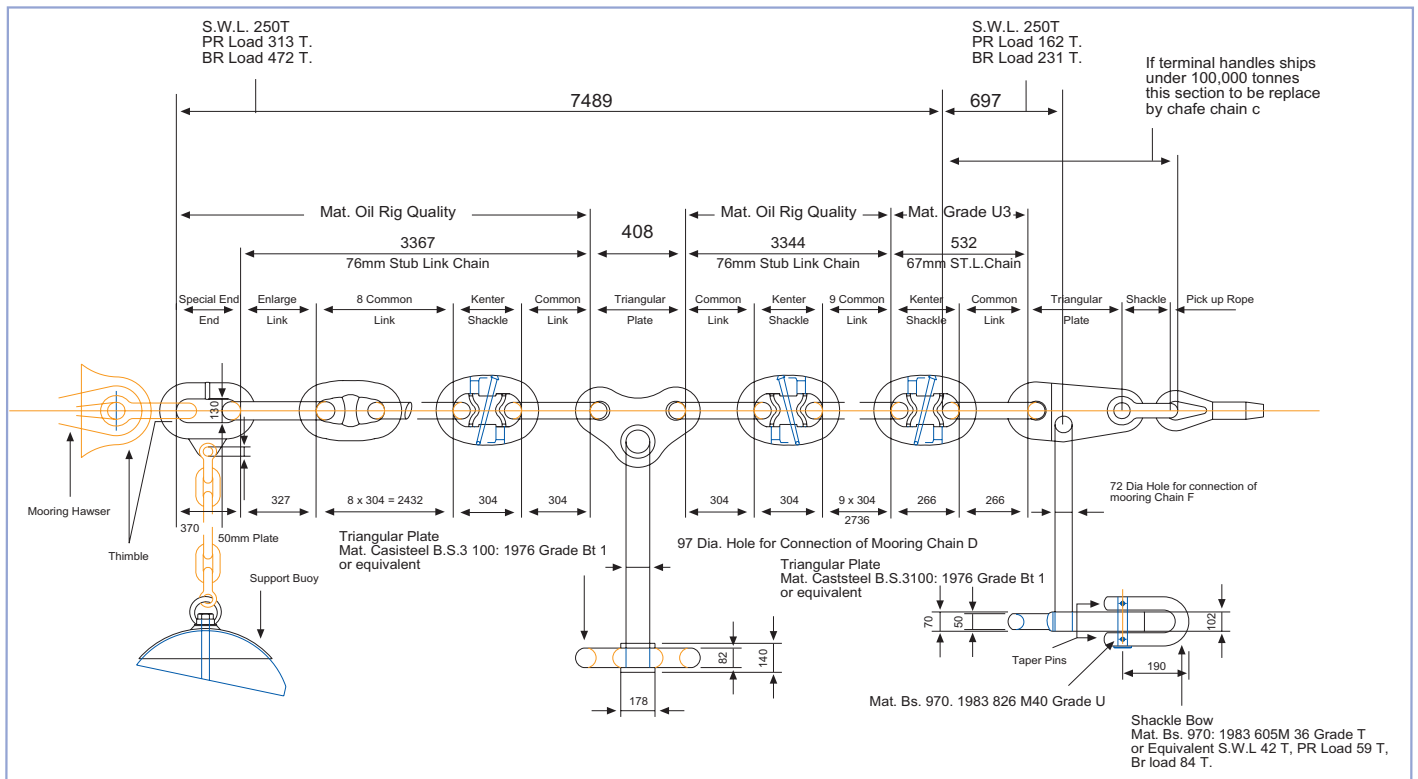

### Chafe Chain B for Ship between 100,000 and 350,000 ton DWT

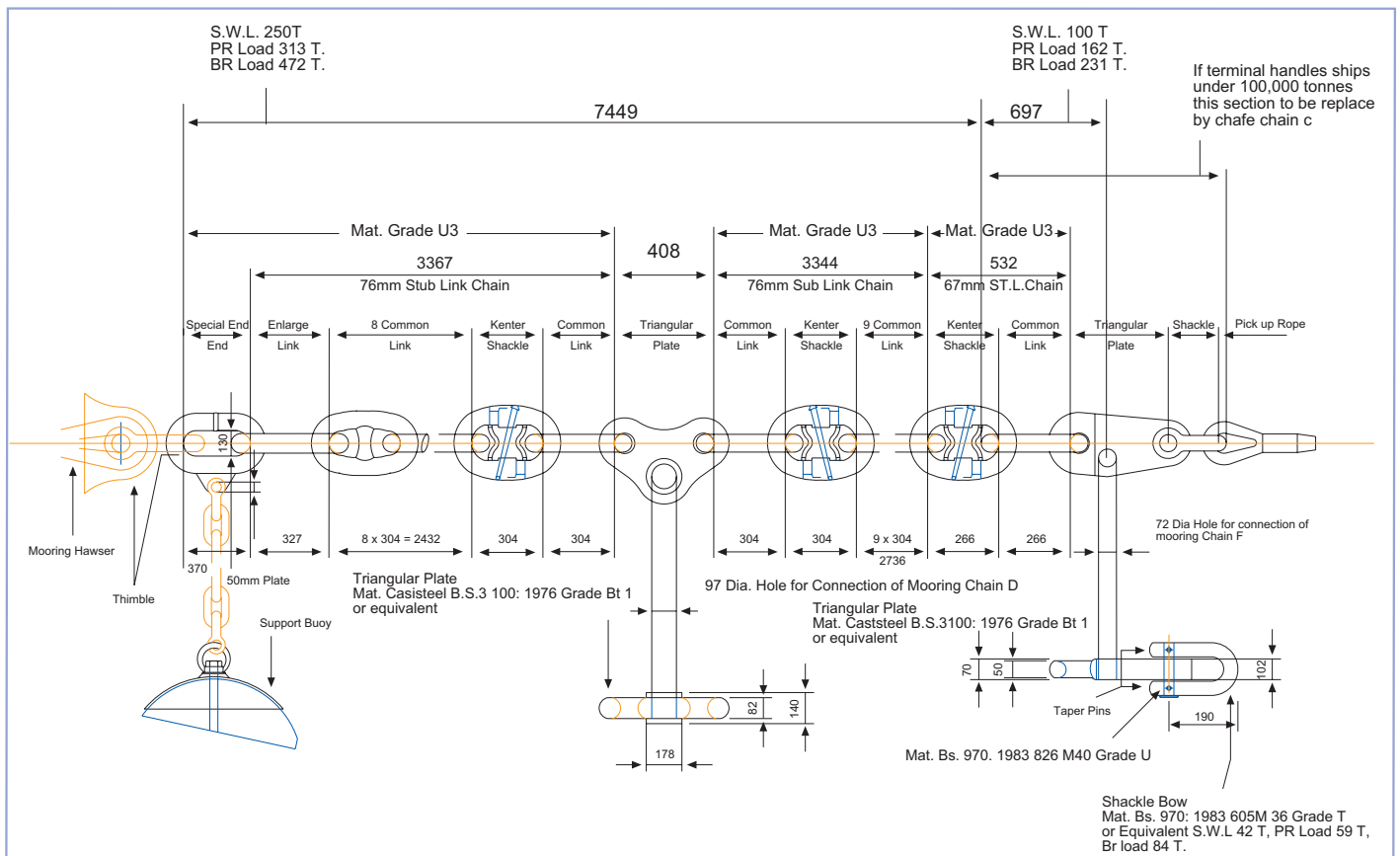

www.marinehub.com